

## Warranty

Unless other agreements or exceptions have been made as regards for example discounts for account of warranty etc, Caféco UK shall apply the following conditions of warranty :

All Caféco products are warranted against defective materials and/or workmanship for the period of 12 months from the date of purchase. The product must be used according to the instructions referred in the operating manual, according to the intended use it was conceived for. Any other use is to be considered as improper and hence dangerous. This warranty does not cover damage due to accident, mis-use, scale or cleaning related faults. If this product is determined to be defective in material or workmanship, Caféco will, at its option, repair or replace the product free of charge. Carriages relating to shipping to and from Caféco to inspect or repair and for the shipping of spare parts are excluded from this warranty.

Proof of purchase in the form of a bill of sale or receipted invoice as evidence that the Product is within the warranty period must be presented to obtain warranty service.

The warranty shall be void if the product is improperly installed, maintained, serviced or repaired by any party other than an authorised Caféco distributor, or subjected to conditions other than those recommended by Caféco in the operating manual. Damage of any kind due to transport is excluded.

This warranty does not affect the statutory rights of the consumer under any applicable national laws in force nor the rights of the consumer against the distributor arising from their sales/purchase contract. This machine is manufactured in Italy.

 **Warning :** Use only genuine spare parts available from your distributor or direct from Caféco UK, at [www.cafeco.co.uk/support](http://www.cafeco.co.uk/support)

**Your Distributor :**



## Operators Manual



## Espresso Pod Verona

( 30-1002 ) VERONA.04a

## **Congratulations !**

On purchasing your new Caféco coffee maker. Please read this manual carefully and follow the instructions specified. The correct use and care will insure long life for the equipment and help avoid any hazards.

## **UK Support**

At Caféco our goal is to insure that your new machine works perfectly right from the start and for many years to come. In case you need to replace or repair any component, please refer to your distributor or contact our support team.

**Internet :** www.cafeco.co.uk/support  
**Email :** support@cafeco.co.uk  
**Fax :** 0870 138 8171, Att. Support

You will need to quote your serial number, this can be found on the rear of the machine. Please have this ready before contacting us.

## **Knowing your machine**

The Verona family of espresso pod machines uses a practical and hygienic system of pre-packed roasted and ground coffee pods. The optional milk frothing device make foaming milk very simple, clean and easy.

### Machine Features

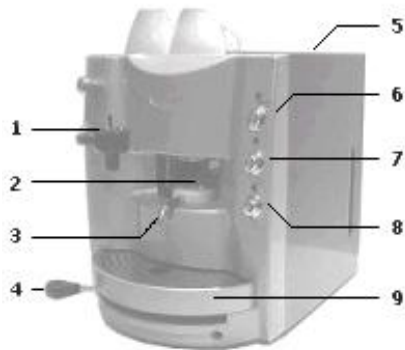

- 1a: Hot water outlet
- 1b: Milk Frother ( Optional )
- 2: Pod Chamber
- 3: Hot Water Spout
- 4: Pod Holder Lever
- 5: Water reservoir lid
- 6: Power Switch
- 7: Coffee Brew Switch
- 8a: Hot Water Switch
- 8b: Milk Frother Switch
- 9: Drip/Waste Tray

## **Maintenance and cleaning**

**Warning :** Before carrying out any cleaning or maintenance operations, always remove the plug from the power mains.

### Cleaning Pod Chamber

After each session or on a regular basis we suggest rinsing the pod chamber to reduce coffee build up. Slide lever (4) to the right, place a container under the brewing spout (3) and press the brew button (L2). Run for 30 seconds and repeat operation 2-3 times. On a monthly basis we suggest using coffee cleaning detergent tablets to remove coffee oils and residue.

### Cleaning Cappuccino Frother (1b) optional

Clean the frother (1b) every time you have finished using the machine or before any long pause in use. Insert suction pipe into a container of cold water, position an empty container underneath frother (1b). To start rinse cycle press switch (S3), flush for 15-20 seconds. Frothing device (1b) can also be removed for detailed cleaning/soaking. Also clean the suction pipe of milk residuals.

### Cleaning the Outside Casing & Drip Tray

On a daily basis take out the grill and drip tray (9), empty, wash and dry thoroughly before reinserting. Using a sponge or soft cloth, wash casing with a non abrasive neutral detergent. Rinse and dry.

**Warning :** Do not bathe machine in water or other solutions, do not use abrasive sponges, powders or solvents.

### Cleaning water reservoir and changing filter

We suggest you clean the reservoir in case of occasional use or when it is completely emptied. To remove, open lid (5), disconnect pipes from reservoir tank and lift upwards. Clean tank thoroughly using a neutral detergent and rinse. Replace, reinsert the pipes and carry out operation as described in 'setting up procedure'. Depending on water hardness change filter every 6 months.

### Pod Holder Settings



After some time, coffee leakage may occur, you can adjust the pod holder. Using the 2mm allen key supplied, loosen the lock screw located on the side of the pod holder (2). Turn the setting ring nut slightly anticlockwise. Test the setting, close the pod holder by sliding the lever (4) to the right until optimal setting is achieved. If the problem is not solved contact service engineer.

### Using Automatic IDEA Cappuccino Frother ( Optional ) ( 1b)



When the red warning lamp (L3) is off, this indicates the boiler has reached the correct temperature. Immerse the clear suction pipe (18) attached to the frother into the container of milk. Position the cup underneath the frothing device (1b). Press switch (S3) to start milk flow for the cappuccino, release switch to stop milk flow.

 Important, clean frother regularly to insure a good foam. Follow cleaning instructions on page 7.

### Hot water

If your machine is fitted with the hot water outlet (1a) then, place you cup under the outlet (1a) and press switch (L3) to dispense hot water.

You can also draw hot water for topping up drinks by simply closing the pod chamber **without** adding a coffee pod, by sliding the lever (4) across to the right. Place you cup under the spout (3). Then press the coffee brew switch (L2) and water will be dispensed from the spout (3). Press switch again to stop.

### Troubleshooting

Should the appliance not work, check the following :

- The plug is connected to the power mains.
- The on/off switch (S1) is on and the lamp (L1) is illuminated.
- The is a water reservoir is at the correct level.
- The mains water valve is open and the hose is connected.
- The milk is not coming out of the frother, check the tube is clear and the it is inserted into the bottom of the milk container.

Always pre-heat ceramic cups using the hot water before brewing coffee.

If after having checked all of these, the machine should not work, refer to your distributor whose address you can find on the back cover of the manual. You can also contact our support team, details can be found on the inside front cover.

### Water level check

If the water in the reservoir is low, the pump will be very loud. To restore the level, refill without removing the tank. If the tank is removed ( for cleaning ) repeat the operations as described in the 'setting up procedure'.

### Technical Data



Power : 230v 50hz 1200w 2.5amp  
Dimensions : 300h x 255w x 355d  
Weight : 13.5kg



According to the council directives 73/23, CEI EN 60335 and their following modifications, the verona range complies with the essential requirements stated by the above mentioned directives.

### General Information



Please note this symbol when reading this manual, this informs the operator of serious safety information.



Please note this symbol, when reading this manual, this informs the operator of important information.

### Safety First !

Read this operators manual carefully.  
Do not use this appliance for anything other than its intended use.  
Do not immerse the appliance, power cord or plug in water or any other liquids.  
Do not touch the heated metal parts with bare hands, more importantly the hot water and brewing spouts. Use a dry cloth  
Do not place fingers inside the brewing chamber during coffee delivery.  
Do not leave the machine at temperatures below 0°c unless you have emptied the water from the boiler first ( contact an authorised service engineer )  
Always unplug the machine before cleaning or maintenance.  
Do no insert finger, hands or metal objects into the openings in the machine body.  
Do nor remove any screws from the machine  
The machine does not contain any part which could be repaired by the user yourself. Refer to your distributor for servicing or maintenance work.



**Warning :** Keep this operators manual hand for future reference

## Installation

### Unpacking the machine

The packaging consists of a carton box with inside die-bland reinforcements. After having taken the appliance out of its packaging, put it on a steady surface, making sure there is room enough to carry out the setting up procedures.

**Warning :** Do not leave the machine where temperatures may drop below freezing 0°C without first emptying the boiler, refer to a service agent.

### Set up procedures

#### Fill Water

Open the water reservoir lid (5) and fill the reservoir container with fresh cold water, making sure that the pipes are properly inserted into the reservoir.

**i** Use filtered or decalcified drinking water, or fit a scale reduction device to prolong the life of your machine. This should be changed after 700-800 drinks are made.

#### Connection to the mains power

Make sure the on/off switch (6) is off, then connect plug to main socket,

**Warning :** Use socket suitable to plug connected, only an authorised electrical engineer should change the plug. Use only a socket that is properly earthed.

#### Priming

Press the on/off switch (6), its red led light (L1) will be on. Press the coffee brew button (7) immediately for 3 seconds, then switch off. Repeat this action three times or until a steady flow of water from the spout (3), this confirms the boiler has been primed.

**Warning :** The pump may be loud at first until the priming cycle has removed airlocks from the system. This loud noise will also indicate that the water reservoir is empty.

**i** When the red/green warning lamps (L2 & L3) are off the machine has reached its optimal temperature and is ready to use. These lamps will go on and off during normal use to keep the boilers at the correct temperatures.

## Controls and Signals (CL)

S1: Power On/Off Switch  
S2: Coffee Brew Switch  
S3: Milk Frother Switch

L1: Power Confirmation Lamp  
L2: Boiler/Element Heating Lamp  
L3: Boiler/Element Heating Lamp

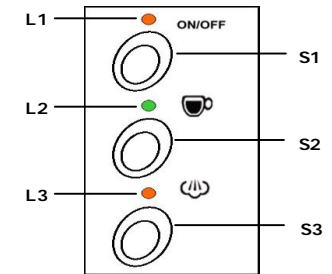

## Instructions For Use

**Warning :** Before use, please make sure that the pod chosen is compatible with the verona pod machines.

**Warning :** Keep hands away from the heated parts the coffee brewing spout (3) and steam/water outlet (1) when in use, to avoid getting burnt.

**i** After first installation, perform one functional cycle by inserting a coffee pod and brewing a long coffee. This will allow the discharge of water which was used to prime the boiler.

### Brewing Coffee



Wait for the red warning light (L2) to turn off, which indicates the machine is at the correct brewing temperature and ready to brew coffee. Place the pod into the brewing chamber (2), slide lever (4) to the right ensuring this locks in place. Place cup under spout (3) and press brew switch (S2) coffee will begin to pour into cup, press switch again to stop when desired level is reached.

**Warning :** Keep fingers away from chamber (2) during coffee brewing.